



Australian Government

Department of Infrastructure, Transport,
Regional Development and Local Government

National Code of Practice.

BUILDING SMALL TRAILERS.

INFORMATION FOR MANUFACTURERS AND IMPORTERS.

Summarised design and testing construction requirements for trailers that do not exceed 4.5 tonnes aggregate trailer mass.



Vehicle Standards Bulletin 1

Revision 5
June 2009

Department of Infrastructure, Transport, Regional Development and Local Government
- Vehicle Safety Standards
GPO Box 594 Canberra ACT 2601
Telephone (02) 6274 6838 Fax (02) 6274 7477

Vehicle Standards Bulletin 1

TABLE OF CONTENTS

1. SCOPE.....	3
2. INTRODUCTION.....	3
3. THE APPLICABLE ADRs.....	3
4. THE PURPOSE OF THIS BULLETIN.....	3
5. RECORD KEEPING.....	4
6. CONDITIONS RELATING TO NON-COMPLYING ROAD TRAILERS.....	4
7. VEHICLE PLATE.....	5
8. VEHICLE IDENTIFICATION NUMBER (VIN).....	6
9. REGISTRATION.....	6
10. RESPONSIBILITY FOR SAFETY.....	7
11. TECHNICAL REQUIREMENTS - Types of trailer covered under VSB1.....	8
12. DEFINITIONS.....	12
13. LIGHTING.....	15
14. ELECTRICAL WIRING.....	24
15. BRAKING.....	26
16. DRAWBARS, SAFETY CHAINS, SAFETY CHAIN ATTACHMENTS AND COUPLINGS.....	26
17. WHEEL GUARDS (MUDGUARDS).....	30
18. VISIBILITY OF TRAY.....	30
19. AXLES AND SUSPENSIONS.....	31
20. WHEELS AND TYRES.....	32
21 DIMENSIONS.....	32
22 GENERAL CARAVANS REQUIRMENTS.....	34
23. GENERAL REQUIREMENTS FOR TRAILERS.....	34
24. TRAILERS & CARAVANS EQUIPPED WITH REFRIGERATION AND AIR CONDITIONING SYSTEMS.....	35
25 IMPORTING A TRAILER INTO AUSTRALIA.....	35
26. TO ORDER THE ADR CD-ROM.....	36
27. USEFUL CONTACTS.....	37
28. APPENDIX 1.....	38

Vehicle Standards Bulletin 1

1. SCOPE

This Vehicle Standards Bulletin applies to road trailers – including new trailers or used imported trailers – with an aggregate trailer mass (ATM) of 4.5 tonnes (4,500kg) or less.

2. INTRODUCTION

Before a road trailer can be registered for the first time in Australia or used on a public road, it must meet the requirements of the *Motor Vehicle Standards Act 1989* (the Act). The Act applies to all new and used imported vehicles.

The Australian and State and Territory Governments jointly maintain a federal system for regulating supply to the market of road vehicles. The system establishes national design and performance standards for vehicles. These standards are known as Australian Design Rules (the ADRs). Amongst other matters, the ADRs are designed to make vehicles safe for use on the road.

The Australian Government maintains jurisdiction over road vehicles up to the point of first supply to the Australian market (i.e. manufacture or importation). Once a vehicle has been supplied to the market, it is "in-service". State and Territory Governments are responsible for continued regulation after this point (e.g. vehicle registration, roadworthiness and the approval of modifications to vehicles in-service).

3. THE APPLICABLE ADRs

A range of ADRs apply to road trailers. Depending on the type of trailer, these ADRs can include: ADR 1, 6, 13, 23, 38, 42, 43, 44, 45, 47, 48, 49, 51, 61, 62, 63 and 74. Topics include mechanical connections, lamps, reflex reflectors, tyres, brakes, trailer dimensions and trailer markings.

A detailed summary is available from the Departments website, at

http://www.infrastructure.gov.au/roads/motor/design/adr_online.aspx

Copies of the ADRs are available from the Department's website, at

http://www.infrastructure.gov.au/roads/motor/design/adr_online.aspx

4. THE PURPOSE OF THIS BULLETIN.

This Vehicle Standards Bulletin establishes a set of design and construction standards for road trailers (with an ATM of 4.5 tonnes or less) that operate as an alternative to the ADRs.

The standards are based on the ADRs – but are simpler and more practical to use. They offer a low-cost alternative, by eliminating the need for some of the more expensive forms of vehicle testing and evidence that are required under the ADRs.

In particular, the standards reflect the common requirements of the States and Territories for trailers to be registered for road use. The standards set out concrete guidance and clearly-defined processes that are more suitable for individuals and small firms.

Road trailers that meet the standards of this bulletin do not need to be certified by the Australian Government, and do not need to be issued with an identification plate or a used import plate. That is, manufacturers and importers are exempt from the need to apply to the Australian Government and submit detailed evidence based on the ADRs.

Vehicle Standards Bulletin 1

Rather, manufacturers and importers merely need to seek road registration from the relevant State or Territory registering authority. It is the responsibility of the manufacturer or importer to ensure that the trailer meets the standards as set out in this bulletin.

In the event that a manufacturer or importer supplies a trailer to the market that does not comply with the requirements of this bulletin, and no other form of approval was obtained for the vehicle, the manufacturer must take all steps possible to rectify the non-compliance. If the non-compliance cannot be rectified, the manufacturer must recall the vehicle from service and take steps to notify relevant Registration Authorities that the vehicle does not comply with the requirements of this bulletin and should not be registered.

In the event that a manufacturer or importer does not comply with these conditions or continues to supply non-complying vehicles to the market, the Administrator of vehicle Standards may require that all vehicles supplied by the manufacturer undergo a full compliance process and advise state and territory governments that any vehicles supplied by that manufacturer under VSB are not approved for supply to the market.

However if a particular vehicle does not comply with this bulletin, and if it were made to comply it would not be able to perform the function to which it was designed to perform. Manufacturers may apply for approval to supply vehicles of that type under the provisions of Administrators Circular 0-3-6.

5. RECORD KEEPING.

Whilst manufacturers and importers are exempt from submitting detailed evidence based on the ADRs to the Australian Government, manufacturers and Importers must retain records relating to the manufacture, testing or inspection of road trailers for the life of the model and for a period of 10 years after the last road trailer is supplied to the market.

These records must contain sufficient information to establish compliance with this Vehicle Standards Bulletin (e.g. written confirmation from the State or Territory that the LPG installation meets the requirements for road registration) and in addition, they must also identify any components that may have been fitted to a particular road trailer for the purposes tracing components in the event of a safety related defect recall notice.

6. CONDITIONS RELATING TO NON-COMPLYING ROAD TRAILERS.

If a road trailer does not comply with the requirements of the Motor Vehicle Standards Act 1989 (the Act) or this bulletin, the manufacturer or importer is required to:

- a) Conduct a safety investigation into the issues surrounding the non-compliance. This investigation shall report on the cause of the non-compliance, the number of road vehicles affected and any other relevant facts or circumstances. This report should then be forwarded to the Administrator of Vehicle Standards within 14 days.
- b) If an issue of non-compliance is detected the manufacturer or importer is to cease supplying the affected vehicles to the market immediately and to notify owners that the vehicle does not comply and should be withdrawn from service until action can be undertaken to correct the non-compliance.

Vehicle Standards Bulletin 1

- c) The manufacturer must determine if the non compliance is a safety related issue, in which case a voluntary or mandatory recall is to occur in accordance with the *'Procedures for the Rectification of Safety Related Defects in Vehicles and Related Products'* (the Recall Code). In instances where the non compliance is deemed not to be a safety related matter, a manufacturer or importer may utilise a field service campaign to resolve the non-compliance.

7. VEHICLE PLATE

Before registration under the terms of this bulletin, the manufacturer or importer must affix a vehicle plate to the trailer.

The vehicle plate is used instead of the identification plate (for new trailers) or used import plate (for used imported trailers). The vehicle plate provides a clear indication to the State and Territory registering authority – and to owners and the general public – that the trailer is ready for road use. The vehicle plate also provides useful information about the specifications of the trailer.

The vehicle plate must be durable, non-corrosive metal and must be affixed to the vehicle in a position where it may be readily examined.

The vehicle plate must be permanently affixed by pop rivets, hammer drive screws or welding. Affixing plates with adhesives is not acceptable.

The vehicle plate must show at least the following information:

- **Manufacturer's or Importer's Name** (whichever party takes responsibility for the certification statement);
- **Trailer Model;**
- **Vehicle Identification Number** (specified in Section 4);
- **Date of Manufacture** (month/year, e.g. 02/08);
- **Aggregate Trailer Mass** (kg); and
- **The Certification Statement** (specified below).

The certification statement for new trailers is:

This trailer was manufactured to comply with the Motor Vehicle Standards Act 1989.

The certification statement for used imported trailers is:

This trailer is an imported used trailer. It has been modified and assessed as complying with the Motor Vehicle Standards Act 1989.

This plate may also include additional information such as the tyre placard information (specified in Section 16). All information must be legible and embossed, indented, etched or engraved in letters and numbers not less than 2.5 mm high.

[\(Refer to ADR 61/02 Clause 8 for further information\).](#)

Vehicle Standards Bulletin 1

8. VEHICLE IDENTIFICATION NUMBER (VIN)

All trailers must be identified by means of a 17 character Vehicle Identification Number (VIN). The VIN to be used is specified by the International Standards Organisation, known as an ISO VIN. Trailers must be marked with the VIN in accordance with the ADRs.

Some state and territory registering authorities require a VIN to be stamped onto a substantial part of the trailer (i.e. the drawbar) for registration purposes. It is recommended that a secondary VIN be provided, in addition to that specified in Section 6 of this bulletin.

Manufacturers supplying up to 500 trailers per year must obtain their VIN structure from [Australian Standards](#) Ltd or their state or territory registration authority.

Where a used imported trailer has a 17 character VIN issued by its original manufacturer, this VIN will be listed on NEVDIS at the time an import approval is issued. If the VIN is something other than a 17 character VIN, an appropriate VIN will be issued by vehicle safety standards and listed on NEVDIS.

Manufacturers supplying more than 500 trailers per year must contact the National Vehicle Identification Coordinator at the NEVDIS Administration Unit on Ph. 02 9218 6546 for information about their VIN structure and about the method of reporting their VINs.

[\(Refer to ADR 61/02 Clause 5 for further information\).](#)

9. REGISTRATION

Registration of trailers remains the responsibility of the State and Territory registration authorities. Trailer manufacturers or importers should consult the relevant authority for the necessary registration procedures, such as inspection.

[\(Refer to the local registration authority for further information or click here to go to the VSB1 Contact Page\).](#)

9.1 Registration Plate (Number Plate)

Provision must be made for mounting of a 372 mm x 136 mm registration plate to the rear of every trailer so that no part of the plate is more than 1300 mm above the ground.

Vehicle Standards Bulletin 1

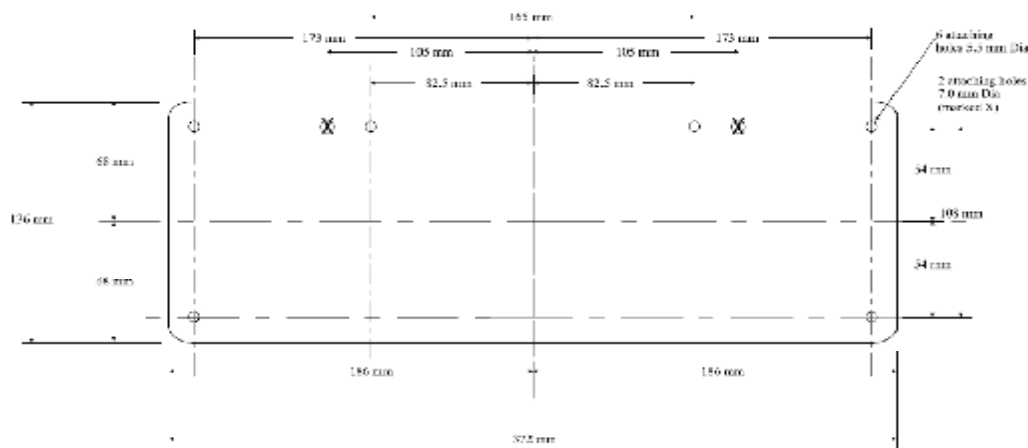

Figure 1 - Registration Plate

TOLERANCES
External Dimensions +1mm
Diameter of Fixing Holes +0.5 mm
Other Dimensions ± 0.5 mm

[\(Refer to ADR 61/02 clause 9 for further information\).](#)

9.2 Registration Label Holder

Trailers are required to display a registration label on the left hand side of the trailer. If there is no window in this location (such as would be found on a caravan), a registration label holder must be fitted on the left hand side of the vehicle.

[\(Refer to ADR 61/02 clause 9.2 for further information\).](#)

10. RESPONSIBILITY FOR SAFETY

Manufacturers and importers should note that they have a responsibility for the overall safety of their trailers. Manufacturers and importers should be aware that the *Trade Practices Act 1974* allows for mandatory recall and rectification of vehicles with safety related defects that will or may cause injury. The responsibility for recall lies with the manufacturer or importer, whoever is the supplier (distributor) in Australia.

The procedures for recall are contained in '*Procedures for the Rectification of Safety Related Defects in Vehicles and Related Products*' (the Recall Code).

The Recall Code is available at the following website:

<http://dynamic.infrastructure.gov.au/recalls/index.asp>

Alternatively, it is available via a written request made to:-

**Department of Infrastructure, Transport, Regional Development and Local Government
Vehicle Safety Standards
GPO Box 594
CANBERRA ACT 2601**

Vehicle Standards Bulletin 1

11. TECHNICAL REQUIREMENTS - Types of trailer covered under VSB1.

11.1 Pig Trailer

A trailer having one axle group near the middle of the length of its goods carrying surface.

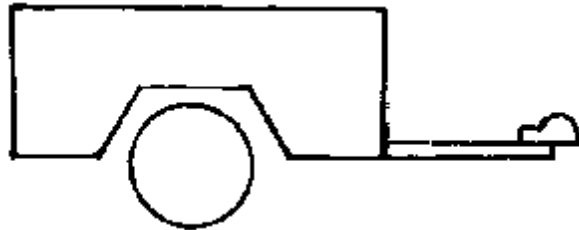

11.2 Dog Trailer

A trailer with 2 axle groups of which the front axle group is steered by connection to the drawing Vehicle.

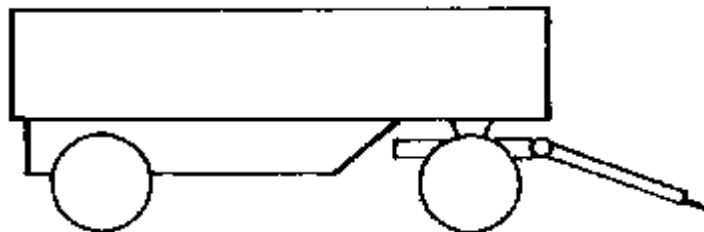

11.3 Semi-Trailer

A trailer having one axle group towards the rear end of the length of its goods carrying surface such that significant load is imposed on the drawing vehicle. Or some of the goods carrying surface is over the towing vehicle.

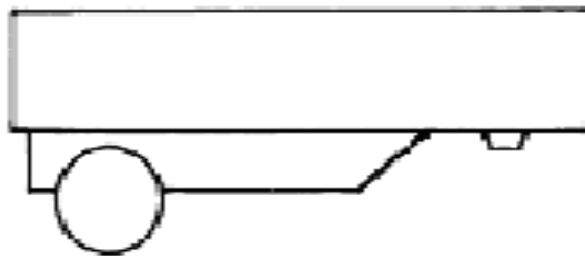

Vehicle Standards Bulletin 1

Typical Examples of Trailers Covered by this Bulletin

11.4 Caravan

An enclosed trailer, which is intended for use as a mobile home or living quarters when parked. It will usually provide fixed sleeping accommodation and/or facilities for the preparation of food. A trailer permanently equipped with a folding and stowable roof (such as a camper trailer) is a caravan. Enclosed trailers constructed for the accommodation of people when parked such as workers' amenity trailers, mobile kitchens or mobile offices are also regarded as caravans.

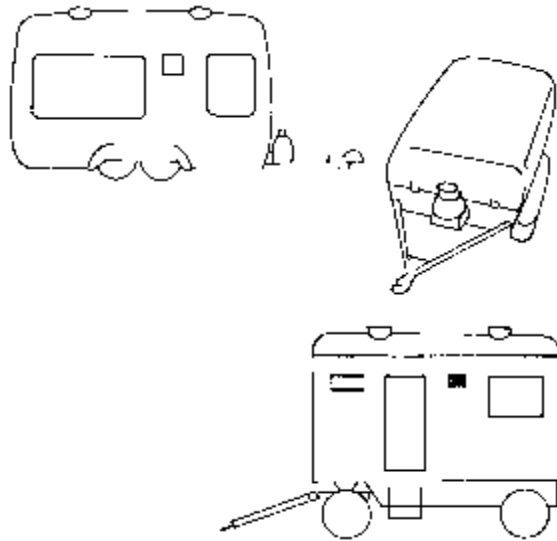

11.5 Box Trailer

A general-purpose trailer with a load space, which is bounded by vertical sides. This category includes a box trailer fitted with a canopy but which is not equipped as a caravan, e.g. is equipped with temporary sleeping accommodation only.

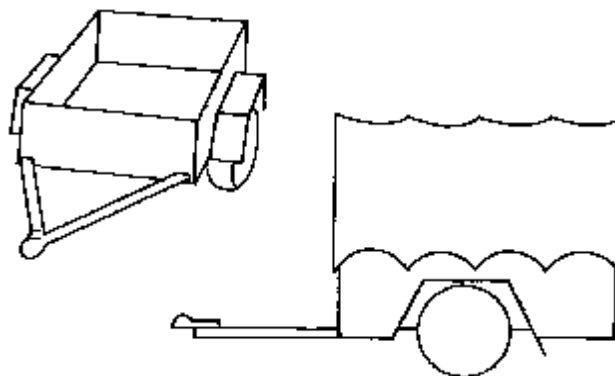

Vehicle Standards Bulletin 1

11.6 Tray Body (Table Top) Trailer

A general-purpose trailer with flat load deck, which is not bounded by vertical sides.



11.7 Boat Trailer

A trailer built specifically to carry a boat.

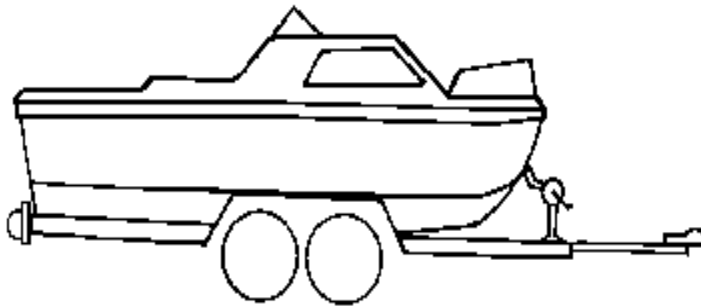

11.8 Car Trailer

A trailer built specifically to carry a motor vehicle such as a passenger car or racing car.

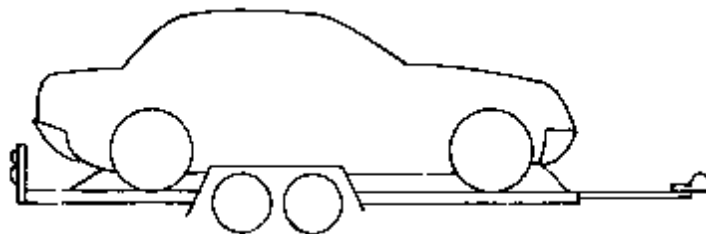

Vehicle Standards Bulletin 1

11.9 Horse Float

A trailer built to carry one or more horses or other similar livestock.

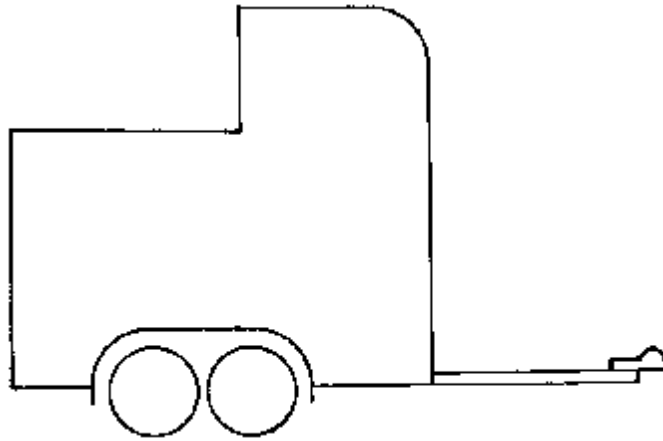

11.10 Plant Trailer

A trailer which, instead of a load space, has fixed to it machinery such as an air compressor, concrete mixer or drilling rig.

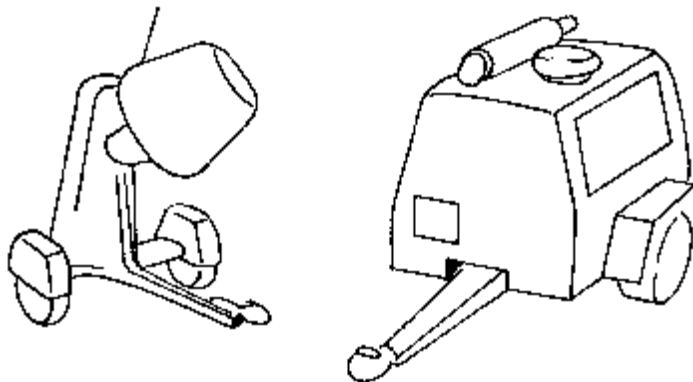

Vehicle Standards Bulletin 1

12. DEFINITIONS

12.1 The Act

Means the [Motor Vehicle Standards Act 1989](#).

12.2 The ADRs

The ADRs mean the [Australian Design Rules](#). Note: The Australian Design Rules are national standards determined by the Australian Government under section 7 of the Act.

12.3 Road Trailer

A road trailer has the same meaning as under the Act.

Note: Under section 5 of the Act, a road trailer means:

- a vehicle without motive power designed for attachment to a road motor vehicle; or
- a piece of machinery or equipment that is equipped with wheels and designed to be towed behind a road motor vehicle.

12.4 Trailer Categories

[VERY LIGHT TRAILER \(TA\)](#) - A single-axle trailer with a GTM not exceeding 0.75 tonne.

[LIGHT TRAILER \(TB\)](#) - A trailer with a GTM not exceeding 3.5 tonnes, other than a trailer of Category TA.

[MEDIUM TRAILER \(TC\)](#) - A trailer with a GTM exceeding 3.5 tonnes but not exceeding 10 tonnes.

12.5 Aggregate Trailer Mass (ATM)

[ATM](#) is the total mass of the trailer when carrying the maximum load recommended by the manufacturer. This includes mass imposed onto the towing vehicle when the combination vehicle is resting on a horizontal supporting plane.

12.6 Gross Trailer Mass (GTM)

[GTM](#) is the mass transmitted to the ground by the tyres of the trailer when coupled to a towing vehicle and carrying the maximum load recommended by the manufacturer or importer, approximately uniformly distributed over the load bearing area.

12.7 Tare Mass

[Tare Mass](#) is the total mass of the trailer when not carrying any load, but when ready for service, unoccupied (if relevant) and with all fluid reservoirs (if fitted) filled to nominal capacity except for fuel, which shall be 10 litres only, and with all standard equipment and any options fitted. This includes any mass imposed onto the drawing vehicle when the combination vehicle is resting on a horizontal supporting plane. (Fluid reservoirs do not include water tanks and waste water tanks fitted to caravans).

12.8 Length (Total Length)

[Length](#) is the longitudinal distance between the 'Front End' and the 'Rear End' of a vehicle.

Vehicle Standards Bulletin 1

12.9 Width (Overall Width)

Width is the maximum distance measured across the body including wheel guards, but excluding rear vision mirrors, signalling devices and side-mounted lamps.

12.10 D-Value

D-Value is the theoretical horizontal reference force between towing vehicle and trailer.

12.11 V-Value

V-Value is the theoretical vertical reference force between towing vehicle and trailer.

Note



These definitions are in accordance with the ADRs. These may differ from other definitions generally in use. A complete list of definitions is available on the ADR CD-ROM. See 35 to order a copy of the ADR CD-ROM or at http://www.infrastructure.gov.au/roads/motor/design/str_subscriptions.aspx.

Vehicle Standards Bulletin 1

12.12 The difference between a trailers ATM and GTM.

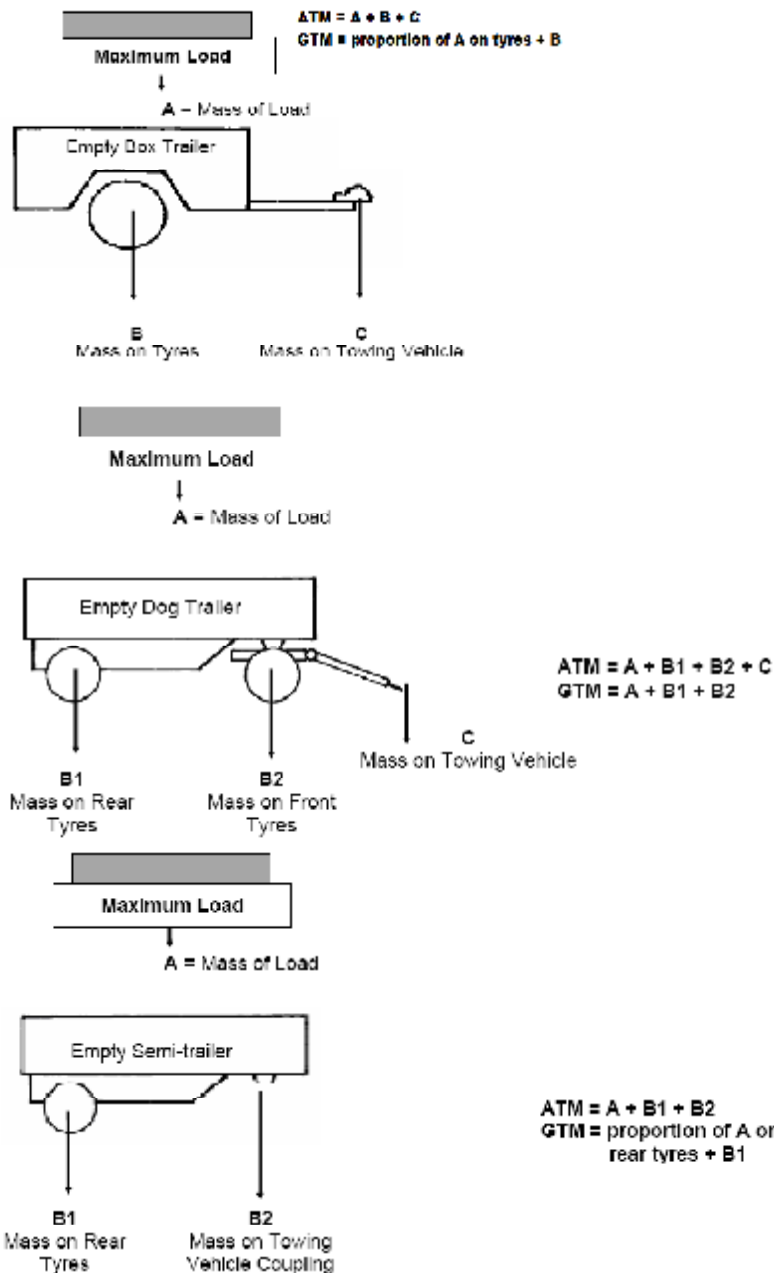

Note



Except for semi-trailers, the difference between the ATM and GTM is usually small.

Vehicle Standards Bulletin 1

13. LIGHTING.

The requirements specified in the ADRs for the performance and installation of lamps and reflectors are based on the regulations set by the United Nations Economic Commission for Europe (ECE).

The performance requirements usually involve tests done in a laboratory to show compliance. Trailer manufacturers must ensure that the lamps and reflectors fitted to their trailers comply with these performance requirements.

This may be done by:

using lamps and reflectors where the lamp manufacturer provides a written assurance that the item (suitably identified) complies with the ADR applicable to its recommended use when fitted according to the instructions supplied. This is either through having either a Component Registration Number (CRN) listed on the Road Vehicle Certification System (RVCS) at <http://rvcs.dotars.gov.au/>. CRNs can be checked by entering the number given by the component manufacturer into the approval number field on the [Vehicle / RVD search page](#) or through an internationally based ECE approval (see below);

or by having the lamps and reflectors tested to the ADR requirements and obtaining from the laboratory conducting the tests, a test report including the conclusion that the item complies with the ADR applicable to its intended use when fitted according to the instructions supplied with the report;

and in either case, fitting the lamps and reflectors according to the instructions provided, making sure that no part of the trailer or its equipment obstructs the lamp output.

The trailer manufacturer must retain these documents in case verification of compliance is needed.

Lamps and reflectors complying with certain international regulations, referred to as ECE Regulations, are acceptable as complying with some of the lighting ADRs. These ECE Regulations are identified in the table on page 16.

Unlike lamps directly approved to an ADR, lamps certified to ECE requirements as the basis of compliance with the corresponding ADR requirements will provide an ECE approval mark on the lens or body of the lamp. This can be used for identification of the component against the written assurance provided with each item. Both ECE approved lamps and lamps with a CRN should be accompanied by fitting instructions, to ensure correct orientation and alignment.

A typical ECE approval mark found on a rear direction indicator is as follows:

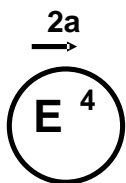

2a – identifies the type of lamp; in this case a rear direction indicator.

4 – identifies the country issuing the ECE approval.

→ – identifies the side of the vehicle towards which the lamp is to be mounted.

6R00217

6R00217 – identifies the ECE approval number; in this case incorporating the ECE Regulation number 6.

Unless specifically mentioned, lamps on a trailer must operate with the corresponding lamps on the towing vehicle, and where pairs of lamps or reflectors are fitted, they must be spaced equally on either side of the centre line of the trailer.

Vehicle Standards Bulletin 1

Lamps on a trailer must not show red light to the front or white light to the rear (except reverse lamp).

A summary of the requirements for each type of lamp and reflector are given in the table below and in the diagrams in the sections that follow. The notation ADR 49/- (for example) refers to the latest version of ADR 49 and ECE R7/- refers to the latest version of ECE Regulation 7.

Lamp	Colour of Emitted Light	Component ADR	Acceptable ECE Markings
Front position lamp	White. May be amber if combined with a side-marker lamp	49/-	ECE R7/-
Rear position lamp	Red	49/-	ECE R7/-
Rear stop lamp	Red	49/-	ECE R7/-
Direction-indicator lamp	Amber	6/-	ECE R6/-
Rear registration plate lamp	White	48/-	ECE R4/-
Hazard warning signal	Amber	6/-	ECE R6/-
End-outline marker lamp	White or amber to the front, red to the rear	49/-	ECE R7/-
Side-marker lamp (Option 1)	Amber to the front, red to the rear	45/-	No ECE approval available
Side-marker lamp (Option 2)	Amber, except for the rearmost lamp which may emit red if it is grouped or combined or reciprocally incorporated with the rear position lamp, the rear end-outline marker lamp, stop lamp or is grouped or has part of the light emitting surface in common with the rear retro-reflector	74/-	ECE 91/- as well as SM1. See text for when SM2 may also be used
Front retro-reflector, non triangular	White or colourless	47/-	ECE R3/-
Rear retro-reflector	Red	47/-	ECE R3/-
Side retro-reflector, non triangular	Amber, except for the rearmost side retro-reflector can be red if it is grouped or has part of the light emitting surface in common with the rear position lamp, the rear end-outline marker lamp, the stop lamp or the red rearmost side-marker lamp.	47/-	ECE R3/-
Reversing lamps	White	1/-	ECE R23/-

Note:

"Grouped lamps" have separate bulbs and lenses (or LED elements) but a common lamp body (e.g. rear position/indicator lamp).

"Combined lamps" have separate lenses but a common bulb (or LED element) and lamp body (e.g. rear position/registration plate lamp).

"Reciprocally incorporated lamps" have a separate bulb but a common or partly common lens and lamp body (e.g. rear position/stop lamp).

[\(Refer to ADR 13/00, for further information\).](#)

Vehicle Standards Bulletin 1

13.1 Front Position (Side) Lamps

These lamps indicate the presence and width of a trailer when viewed from the front.

Presence: Must be fitted if a trailer is more than 1600 mm wide and over 4 metres long, or over 1800 mm wide.

Number: 2.

Arrangement: At the front. See Figure 1. For trailers 2100 mm wide or less, may be combined with 2 side-marker lamps that have been fitted, this being in accordance with Option 1 or Option 2 (see Section 9.8).

Electrical Connections: Must operate with rear position, end-outline (if fitted), side-marker (if fitted) and rear registration lamps.

(For further information, refer to [ADR 13/00 Appendix A clause 6.9](#) and [ADR 49/00](#)).

13.2 Rear Position (Side) Lamps (Tail Lamps)

These lamps indicate the presence and width of a trailer when viewed from the rear.

Presence: Must be fitted.

Number: 2.

Arrangement: At the rear. See Figure 1.

Electrical Connections: Must operate with front position (if fitted), end-outline (if fitted), side-marker (if fitted) and rear registration lamps.

(For further information, refer to [ADR 13/00 Appendix A clause 6.10](#) and [ADR 49/00](#)).

13.3 Rear Stop Lamps (Brake Lamps)

These lamps indicate to the rear of the trailer that the driver is applying the service brakes.

Presence: Must be fitted.

Number: 2.

Arrangement: At the rear. See Figure 1.

Electrical Connections: Must operate with service brake on towing vehicle and (if fitted) service brake on trailer.

(For further information, refer to [ADR 13/00 Appendix A clause 6.7](#) and [ADR 49/00](#)).

13.4 Direction Indicator Lamps (Turn Signals)

These lamps indicate to the rear and the side of the trailer that the driver is intending to change direction to the left or the right.

Presence: Must be fitted.

Number: 2.

Arrangement: At the rear. See Figure 1. One pair of side-repeating indicators may also be fitted approximately half way along semi-trailers that are over 7500 mm long.

Electrical Connections: Must operate by a single control, independently of all other lamps, and must flash in phase all on one side. The flashing must be within the range of 60 to 120 flashes per minute.

(For further information, refer to [ADR 13/00 Appendix A clause 6.5](#) and [ADR 6/00](#)).

Vehicle Standards Bulletin 1

13.5 Rear Registration Plate (Number Plate) Lamp

This lamp(s) illuminates the space reserved for the rear registration plate.

Presence: Must be fitted.

Number: At least 1 (note that some lamps may only have been approved for fitment as a pair).

Arrangement: At the rear and so that the rear registration plate is illuminated. No light is to be directed rearwards.

Electrical Connections: Must operate with front position (if fitted), rear position, end-outline (if fitted) and side-marker (if fitted) lamps.

(For further information, refer to [ADR 13/00 Appendix A clause 6.8](#) and [ADR 48/00](#)).

13.6 Hazard Warning Signal

This is the simultaneous operation of all the trailer's direction indicator lamps to show that the trailer temporarily presents a special danger to other road users.

Presence: See below

Number: See below

Arrangement: See below

Electrical Connections: All direction indicators on the trailer must operate simultaneously with hazard warning lamps of the towing vehicle.

(For further information, refer to [ADR 13/00 Appendix A clause 6.6](#) and [ADR 49/00](#)).

13.7 End-Outline Marker (Clearance) Lamps

These lamps indicate the presence, width and height of a trailer when viewed from the front or rear.

Presence: Must be fitted if a trailer is more than 2100 mm wide.

Number: 2 to the front (white or amber) and 2 to the rear (red).

Arrangement: At the front and the rear. See Figure 1. If a trailer has no structure at the front and at the rear to which lamps can be attached (such as a boat trailer), then one combination white (or amber) /red end-outline marker lamp midway on each side may be fitted instead.

Electrical Connections: Must operate with front position (if fitted), rear position, side-marker (if fitted) and rear registration lamps.

(For further information, refer to [ADR 13/00 Appendix A clause 6.13](#) and [ADR 49/00](#)).

Vehicle Standards Bulletin 1

FIGURE 1
Front and Rear Lamps – Dimensional Limits

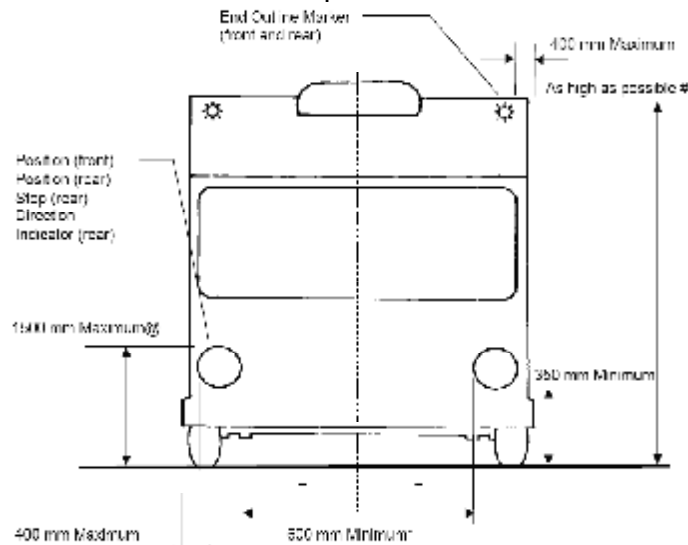

- @ May be increased to 2100 mm if the structure makes it impractical to keep within 1500 mm.
- * May be reduced to 400mm where the overall width of the trailer is less than 1300mm.
- # Compatible with the operational requirements of the trailer and the requirement to keep the dimensions symmetrical on either side.

Note



Front position lamps and front and rear end outline marker lamps are required for wide trailers only. Refer to text.

13.8 Side-Marking (Marker) Lamps

These lamps indicate the presence and length of a trailer when viewed from the side.

Either Option 1 or Option 2 must be met. Option 1 is based on an international standards arrangement (an option may be chosen even if it results in no side-marker lamps having to be fitted to a particular trailer). Both options are shown below.

OPTION 1

Presence: SM1 type lamps must be fitted if a trailer is more than 6000 mm long.

SM1 or SM2 type lamps may optionally be fitted to all other trailers.

Note



SM1 and SM2 lamps have different visibility limits and are not interchangeable.

Number: Such that the Arrangement below is met.

Arrangement: At the side. See Figure 2(a). Trailers that are not more than 6000 mm long may have one lamp fitted each side within the first third and/or one within the last third of the length.

Electrical Connections: No requirement.

Vehicle Standards Bulletin 1

FIGURE 2(a)
Side Lamps – Dimensional Limits (Option 1)

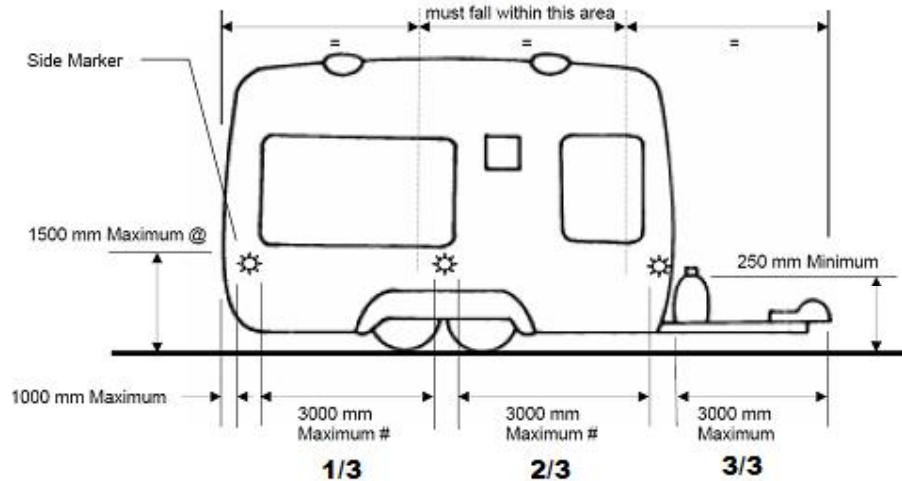

- @ May be increased to 2100 mm if the structure makes it impractical to keep within 1500 mm.
- # May be increased to 4000 mm if the structure makes it impractical to keep within 3000 mm.

Note



Under this option, Side Marker Lamps are only required for long trailers. Refer to text.

OPTION 2

Presence: Must be fitted if a trailer is more than 2100 mm wide or more than 7500 mm long.

Must be fitted to all semi-trailers.

Number: 2 towards the rear if a trailer is more than 2100 mm wide.

2 towards the front plus 2 towards the rear, if a semi-trailer is equal or less than 7500 mm long.

2 towards the front plus 2 towards the rear, plus 2 midway between the front and the rear lamps, if a trailer over 7500 mm long.

Additional pairs of side marker lamps, equally spaced between the front and the rear lamps, may also be fitted, as long as the distances between the centres of adjacent lamps is not more than 5000 mm.

Arrangement: At the side. See Figure 2(b).

In width, the outermost surface of the lamp must not be more than 150 mm inboard of the extreme outer edge of the trailer.

Electrical Connections: No requirement.

(For further information, refer to [ADR 13/00 Appendix A clause 6.8](#) and [ADR 74/00](#)).

Vehicle Standards Bulletin 1

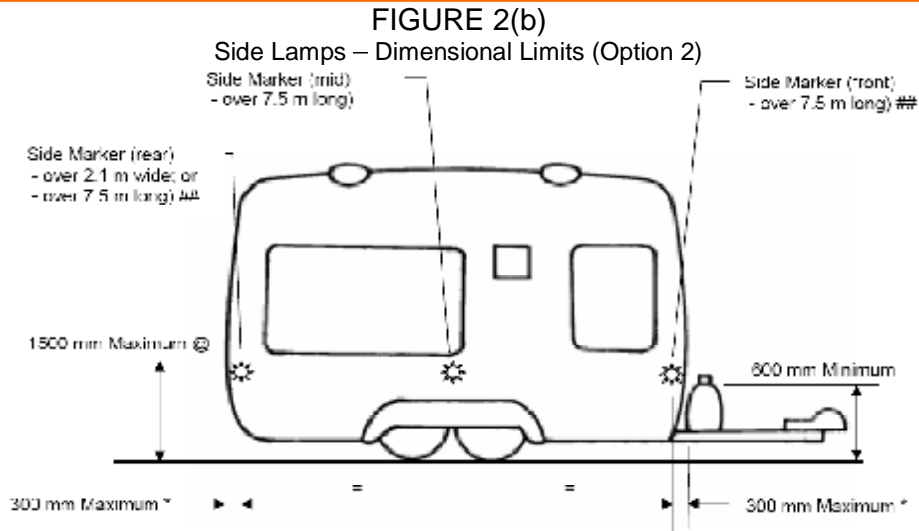

- @ May be increased to 2100 mm if the structure makes it impractical to keep within 1500 mm.
Also all semi-trailers regardless of size.
* May be increased to as close as possible to the front and/or rear respectively if the structure makes it impractical to keep within 300 mm (for example a boat trailer). Where this is the case, and the distance between the front and rear lamps would then be less than 2500 mm, only the rearmost lamps need be fitted.

Note



Under this option, Side-Marker Lamps are only required for large trailers and any semi-trailer. Refer to text.

13.9 Retro (Reflex) Reflectors

Retro-reflectors indicate the presence of a trailer by reflecting light from a separate source.
(For further information, refer to [ADR 13/00](#) and [ADR 47/00](#))

13.10 Front Retro (Reflex) Reflectors (Non triangular)

Presence: Must be fitted. Non-triangular only.

Number: 2.

Arrangement: At the front. See Figure 3.

Electrical Connections: No requirement

(For further information, refer to [ADR 13/00 Appendix A clause 6.16](#) and [ADR 47/00](#))

13.11 Rear Retro (Reflex) Reflectors

Presence: Must be fitted. Triangular or non-triangular.

Number: 2.

Arrangement: At the rear. See Figure 3.

Triangular the apex of triangle must point upwards.

Non-triangular rear retro reflectors are not required to be grouped together with other rear light-signalling devices.

Electrical Connections: No requirement

(For further information, refer to [ADR 13/00 Appendix A clause 6.15 or 6.14](#) and [ADR 47/00](#))

Vehicle Standards Bulletin 1

13.12 Side Retro (Reflex) Reflectors (Non Triangular)

Presence: Must be fitted. Non-triangular only.

Number: Such that the Arrangement below is met.

Arrangement: At the side. See Figure 4.

Electrical Connections: No requirement.

(For further information, refer to [ADR 13/00 Appendix A clause 8.7](#) and [ADR 47/00](#))

FIGURE 3
Front and Rear Retro-Reflectors – Dimensional Limits

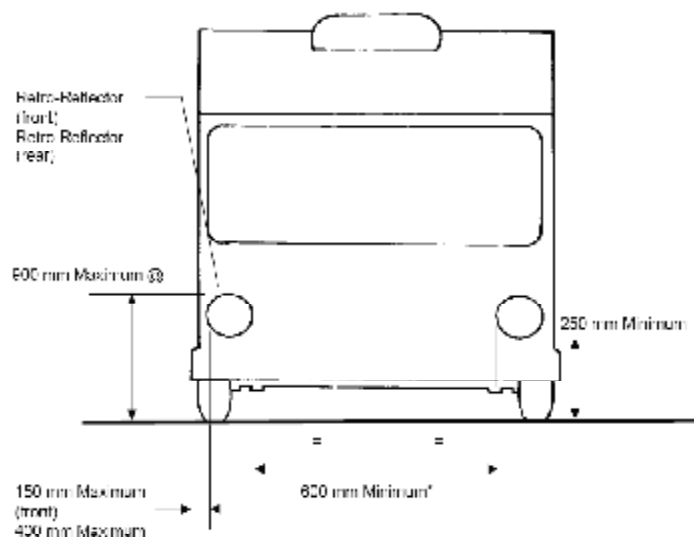

- @ May be increased to 1500 mm if the structure makes it impractical to keep within 900 mm.
- * May be reduced to 400mm where the overall width of the trailer is less than 1300mm.

FIGURE 4
Side Retro-Reflectors – Dimensional Limits

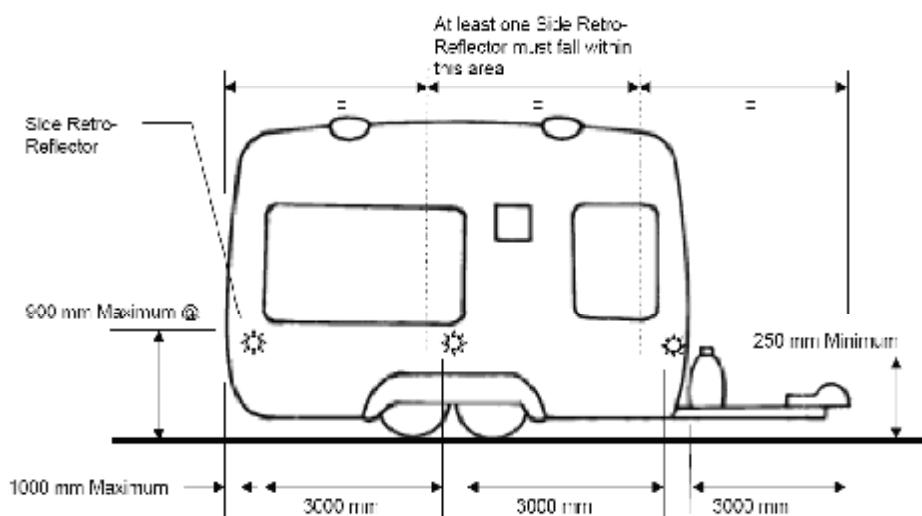

- @ May be increased to 1500 mm if the structure makes it impractical to keep within 900 mm.
- # May be increased to 4000 mm if the structure makes it impractical to keep within 3000 mm.

Vehicle Standards Bulletin 1

Note



Manufacturers should ensure that optional equipment and original equipment, or for after market fitment, does not invalidate compliance with any ADRs. For example, the fitting of equipment near a lamp may effect visibility requirements of the lamp. For more information, refer to Administrators Circular 0-2-4 and ADR 13/00.

13.13 Reversing Lamps

Presence: Optional on all trailers.

Number: 1 or 2 lamps must be fitted on all trailers with a length less than 6,000mm.

2 lamps must be fitted on all trailers with a length greater than 6,000mm.

Arrangement: At the rear.

A minimum height of not less than 250mm from the ground; and maximum height of 1,200mm from the ground.

Electrical Connections: The lamps light up when reverse gear is engaged on the towing vehicle.

[\(For further information, refer to ADR 13/00\)](#)

12.14 Grouping of Rear Lamps

Rear position (side) lamps, stop lamps, direction indicator lamps, registration plate lamps and retro-reflectors may be grouped into the same units, as long as their individual requirements are met. The following are examples of acceptable arrangements.

[\(For further information, refer to ADR 13/00\)](#)

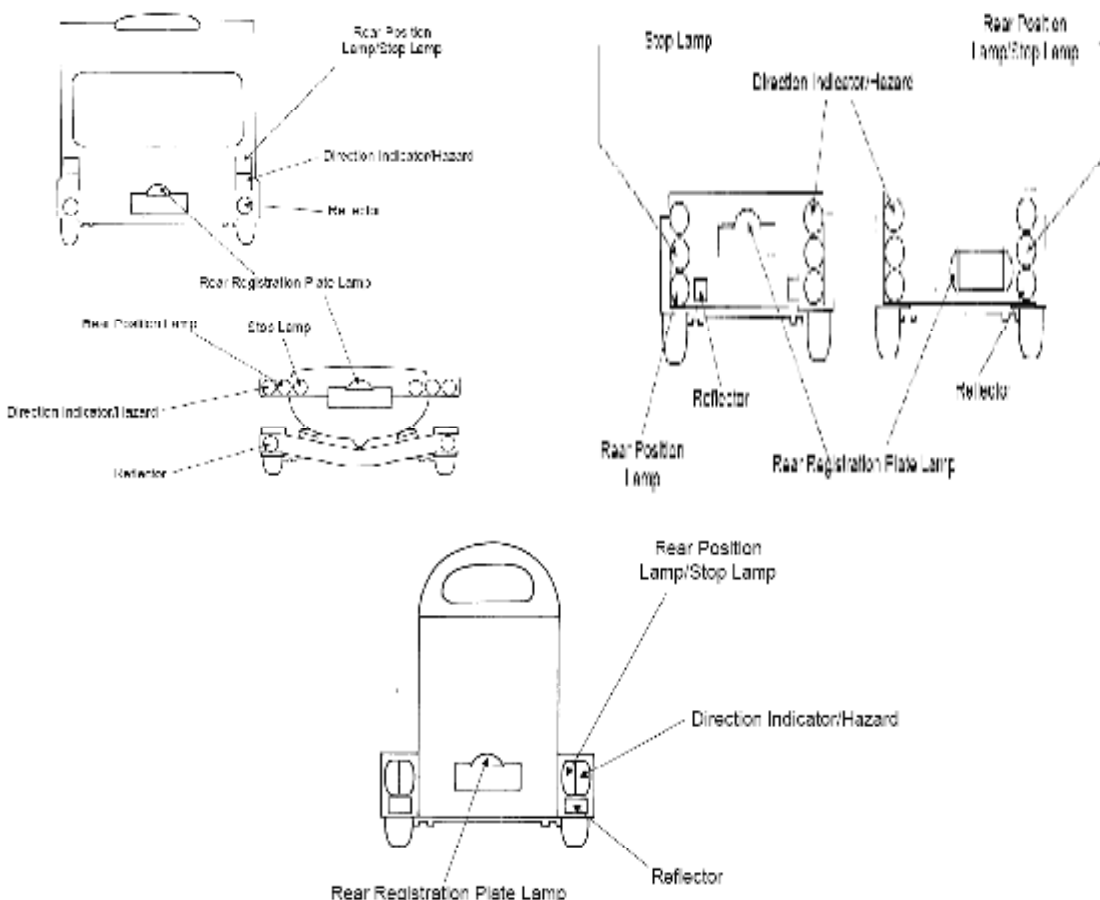

Vehicle Standards Bulletin 1

14. ELECTRICAL WIRING

Trailer wiring must:

- be supported at intervals of not more than 600 millimetres along its length;
- be insulated at joints;
- be located in such a position that it can neither become overheated nor contact moving parts;
- be protected from chafing; and
- have an earth return wire between the trailer and its hauling vehicle; it is not acceptable to use the trailer coupling or a safety chain/cable as an earth.

[\(For further information, refer to ADR 42/04 clause 9\)](#)

Note



Wiring and wiring connections should also be designed to withstand the vibration that they will be subject to during use of the trailer, be of suitable size, and be located in a position where they will not be crushed. Particular care should be taken to ensure that electric brake wiring is adequately shielded from road debris.

Trailers that do not exceed 3.5 tonnes ATM must have electrical connectors between the trailer and towing vehicle that comply with *Australian Standard [AS 2513-1982](#) 'Electrical Connectors for Trailer Vehicles'* or *Australian Standard [AS 4177.5-2004](#) 'Caravan and light trailer components, Part 5: Electrical connectors'*.

Trailers over 3.5 tonnes ATM may use electrical connectors complying with [ISO 1185-2003](#) or [SAE J560-1998](#) Standards for electrical connectors between towing vehicles and trailers as alternative standards. Three types of seven pin connectors are specified in the Standard and their wiring is shown on page 25. Twelve pin connectors are also specified in the Standard.

Note



Seven and twelve pin connectors should be of a robust design to reduce the risk of short circuits developing.

Lamps and wiring may be detachable from trailers such as boat trailers, where they are exposed to conditions such as immersion in water, which might cause short-circuiting or other malfunctions.

Electrical installations on a trailer that are intended for connection to a power system other than that of the drawing vehicle must comply with *[Australian Standard 3001-1981](#) 'Electrical Installations in Caravans and Caravan Parks'* or *[Australian Standard AS 3001-2001](#) 'Electrical Installations – Relocatable premises (including caravans and tents) and their site installations'*.

Vehicle Standards Bulletin 1

	Circuit	Circuit Conductor	Circuit Conductor Colour
7 Pin Connector	1	Left-hand turn	Yellow
	2	Reversing signal	Black
	3	Earth return	White
	4	Right-hand turn	Green
	5	Service brakes	Blue
	6	Stop lamps	Red
	7	Rear lamps, clearance and side marker lamps	Brown
12 Pin Connector	8	Battery charger/electric winch	Orange
	9	Auxiliaries, etc/battery feed	Pink
	10	Earth return	White
	11	Rear fog lamp	Grey
	12	Spare	Violet

Note Because of interchangeability problems that may arise, it is recommended that pin 5 in the 7 pin connectors be used only for service brakes. If auxiliary circuits are required, then the 12-pin type 3 connector would be preferable.

Front view of trailer plugs (Type 1 and Type 2 plugs also have a locating notch at the bottom):

Front view of trailer plugs:

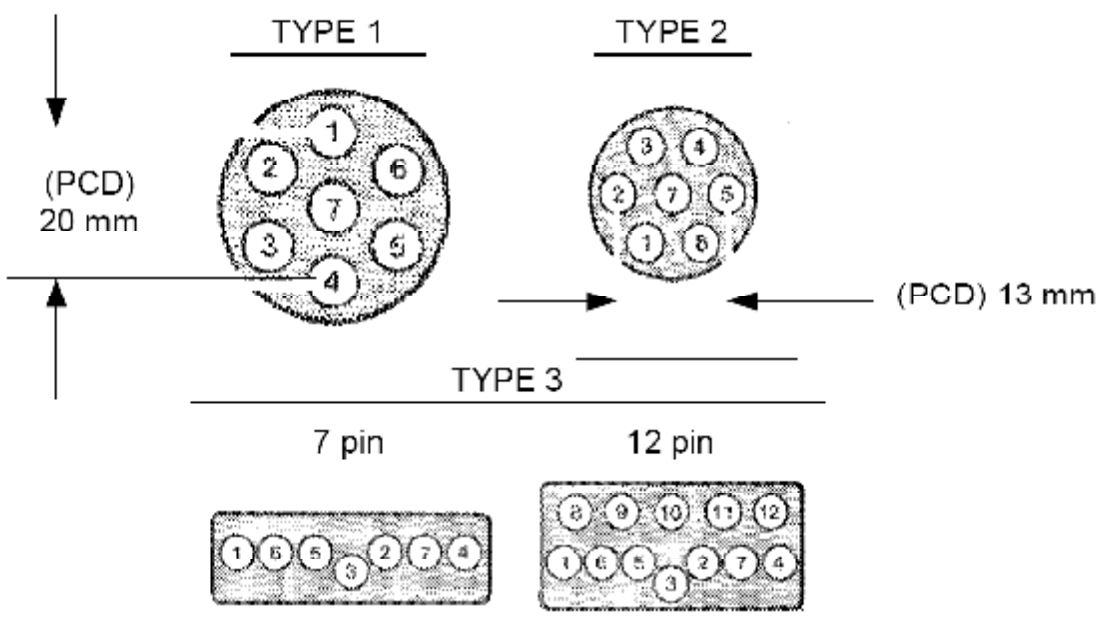

Vehicle Standards Bulletin 1

15. BRAKING

15.1 Trailers that do not exceed 0.75 tonne GTM with a single axle

No brakes are required.

[\(For further information, refer to ADR 38/02 clause 5\)](#)

Note



Two axles with centres spaced less than 1 metre apart are regarded as a single axle.

15.2 All other trailers that do not exceed 4.5 tonnes ATM

These trailers must be fitted with an efficient brake system that complies with ADR 38/-. Except for over-run brakes, all brakes must be operable from the driver's seat of the towing vehicle.

For trailers up 2 tonnes GTM, an efficient braking system is considered to have brakes operating on the wheels of at least one axle. Over-run brakes may only be used on trailers that do not exceed 2 tonnes GTM.

Every trailer over 2 tonnes GTM must have brakes operating on **all wheels**. The brake system must cause immediate application of the trailer brakes in the event of the trailer becoming detached from the towing vehicle. Under these circumstances, the brakes must remain applied for at least 15 minutes.

All flexible hydraulic brake hoses, air or vacuum brake tubing and air and vacuum flexible hoses must conform to SAA, SAE, BS, JIS, DIN, ISO or ECE Standards and be fitted to the vehicle in a way that will prevent chafing, kinking or other mechanical damage under normal motion of the parts to which they are attached.

[\(For further information, refer to ADR 38/02 clause 5\)](#)

Note



Manufacturers should consider the merits of including a parking brake function when designing the braking system. ADR 38/03 clause 8 and 14 provides guidance for parking brake systems.

16. DRAWBARS, SAFETY CHAINS, SAFETY CHAIN ATTACHMENTS AND COUPLINGS

16.1 Drawbars

Drawbars must be securely attached to a substantial portion of the trailer.

Drawbars must withstand the following forces applied at the centre of the intended coupling without detachment or any distortion or failure, which will affect the safe drawing of the towed trailer:

Longitudinal tension and compression (N) $1.5 \times 9.81 \times \text{ATM}$ (kg)

Transverse thrust (N) $0.5 \times 9.81 \times \text{ATM}$ (kg)

Vertical tension and compression for rigid drawbar trailer (N) $0.5 \times 9.81 \times \text{ATM}$ (kg)

[\(For further information, refer to ADR 62/01 clause 14\)](#)

Vehicle Standards Bulletin 1

16.2 Drawbar Safety Chains

All pig trailers with rigid drawbars (with or without breakaway brakes – but excluding converter dollies) and, any other trailer without breakaway brakes, must be fitted with safety chains that are marked in accordance with the relevant Australian Standard and (or cables as applicable) complying with the following:

trailers that do not exceed 2.5 tonnes ATM must have at least one safety chain complying with *Australian Standard AS 4177.4-1994* or *Australian Standard AS 4177.4-2004 'Caravan and light trailer towing components – Part 4: Safety chains up to 3500kg capacity'*, or be a safety cable with a certified load capacity of the same;

trailers over 2.5 tonnes and not exceed 3.5 tonnes ATM must have two safety chains of designation of 3500 kg complying with *Australian Standard AS 4177.4-1994* or *Australian Standard AS 4177.4-2004*;

trailers over 3.5 tonnes ATM must have two safety chains made from steel of a minimum 800 MPa breaking stress that conforms to the mechanical properties of Grade T chain as specified in *Australian Standard AS 2321-1979 'Short Link Chain for Lifting Purposes (non calibrated)'* or *Australian Standard AS 2321-2006 Short Link Chain for Lifting Purposes*. Each chain must be sized such that the minimum breaking load exceeds the ATM.

Caution



Safety chains, which have the mechanical T grade property, are not suitable for welding.

[\(For further information, refer to ADR 62/01 clause 14\)](#)

16.3 Drawbar Safety Chain Attachment Points

Safety chain attachment points are the means by which the safety chains are attached to the drawbar. These points must be located as near as practicable to the tow coupling. Where two points of attachment are required, they must be mounted one on either side of the centreline of the drawbar.

Each safety chain attachment point must be capable of withstanding the following minimum forces without incurring either any residual deformation that would interfere or degrade the function of the assembly, or any breaks, cracks or separation of components:

Longitudinal tension and compression (N) $1.5 \times 9.81 \times \text{ATM}$ (in kg)

Vertical tension and compression (N) $0.5 \times 9.81 \times \text{ATM}$ (in kg).

[\(For further information, refer to ADR 62/01 clause 14\)](#)

Caution



Load levelling bars should only be used with towbars designed for load levelling. Very high forces can be generated when the vehicle and trailer combination travels through dips in the roadway. These high forces may exceed the design limits of the towbar and or its mountings.

Caution



Drawbar safety chain attachment points should not come into contact with the road surface when the trailer is disconnected.

Vehicle Standards Bulletin 1

16.4 Couplings

Trailers that do not exceed 3.5 tonnes ATM must have a quick release coupling which is designed to be engaged and disengaged without the use of tools. It must be of a positive locking type with provision for a second independent device. The locking must be readily verifiable by visual inspection.

For trailers having an ATM of 3.5 tonnes or greater, refer directly to [ADR 62/01](#) or [ADR 62/02](#). Before purchasing a coupling for this size of trailer, you should request from the coupling supplier written confirmation that the coupling complies with [ADR 62/01](#) or [ADR 62/02](#).

All couplings must be marked in accordance with [ADR 62/01](#) or [ADR 62/02](#). These in turn call up various [Australian Standards](#) or (as with lamps and reflectors) an internationally based ECE regulation R55/-. There is also provision for alternative couplings, with marking specified in Clause 12.4 of [ADR 62/01](#) and [ADR 62/02](#).

If you intend to manufacture your own coupling, then you will need to consult [ADR 62/01](#) or [ADR 62/02](#) and conduct physical testing to ensure compliance.

Two common coupling types are outlined below:

16.4.1: 50mm Ball Couplings

Ball couplings used on trailers with an ATM that does not exceed 3.5 tonnes must comply with Australian Standard [AS 4177.3-2004](#) Caravan and light trailer towing components Part 3: Coupling body for ball couplings.

Ball couplings on towbars are required to be installed so that the height of the centre of the body of the ball coupling is between 350mm and 420mm from the ground when laden (Refer to [ADR 62/01](#)). Alternatively, if complying with the requirements of [ADR 62/02](#) the maximum height of the centre of the body of the ball coupling may be increased to 460mm. However, the ball may be installed at any other height, provided it is also capable of being adjusted to at least one height within the 350-460mm range.

The coupling body used on trailers should be designed to be compatible with these heights.

Alternatively, ball couplings may comply with ECE R55/- as Class B coupling heads.

A coupling body complying with AS 4177.3 must be marked with:

- the manufacturer's name or trademark;
- the mark '50';
- the maximum rating for the coupling body in one of the following, as applicable,
 - 750 kg; or
 - 2000 kg; or
 - 3500 kg;
- a code to indicate the serial number, batch, production date, or similar;
- the words 'DO NOT WELD' if the coupling body is manufactured from non-weldable materials;
- the words 'WELD ONLY' if the coupling body is specifically designed to be attached by welding only.

Vehicle Standards Bulletin 1

A coupling body complying with ECE R55/- must be marked with:

- the manufacturer's name or trademark;
- the mark 'B' or 'B50-X';
- the maximum 'D-Value' rating for the coupling body. This corresponds to [Australian Standards](#) based ratings as follows:
 - 750 kg; (D-Value of at least 6.4); or
 - 2000 kg (D-Value of at least 14); or
 - 3500 kg (D-Value of at least 20); and
- the mark 'S', followed by the permissible static vertical load in kg.

[\(For further information, refer to ADR 62/01\)](#)

Caution



The [Australian Standard](#) and ECE standard contain 50mm ball coupling articulation limits. These angular limits are not intended to cover off road operation. Trailers for this type of operation should be designed accordingly.

16.4.2 Fifth Wheel Assemblies and Kingpins

Fifth Wheel Assemblies and Kingpins with a D-Value rating of 40 kN or less

must comply with *Australian Standard* [AS 4968.1-2003 Heavy road vehicles – Mechanical coupling between articulated vehicle combinations, Part 1 Design criteria and selection requirements for fifth wheel, kingpin and associated equipment](#), or to other requirements as listed in [ADR 62/02](#).

Alternatively, they may instead comply with ECE R55/- as Class G fifth wheel couplings and Class H fifth wheel coupling pins.\

A coupling complying with AS 4968.1 must be marked with:

- the manufacturer's name or trademark;
- the size, 'D-value' and the plate thickness (for weld in kingpins) e.g. '50/D40/10';

Note



'M' rated kingpins may be used instead of 'D-value' rated kingpins. Refer to AS 4968.1 for details.

A coupling complying with ECE R55/- must be marked with:

- the manufacturer's name or trademark;
- the mark 'G50' or 'G50-X' or 'H50' or 'H50-X';
- the mark 'D', followed by the 'D-Value' rating for the coupling; and
- the mark 'U', followed by the permissible static vertical load in kg.

The ADR also allows fifth wheel assemblies and kingpins to instead be rated and marked with the allowable ATM, as long as this does not exceed 3.5 tonnes.

[\(For further information, refer to ADR 62/01\)](#)

Vehicle Standards Bulletin 1

17. WHEEL GUARDS (MUDGUARDS)

All wheels of a trailer must be fitted with wheel guards that are designed to protect other road users against thrown-up stones, mud, ice, snow and water and to help prevent people contacting the moving wheels.

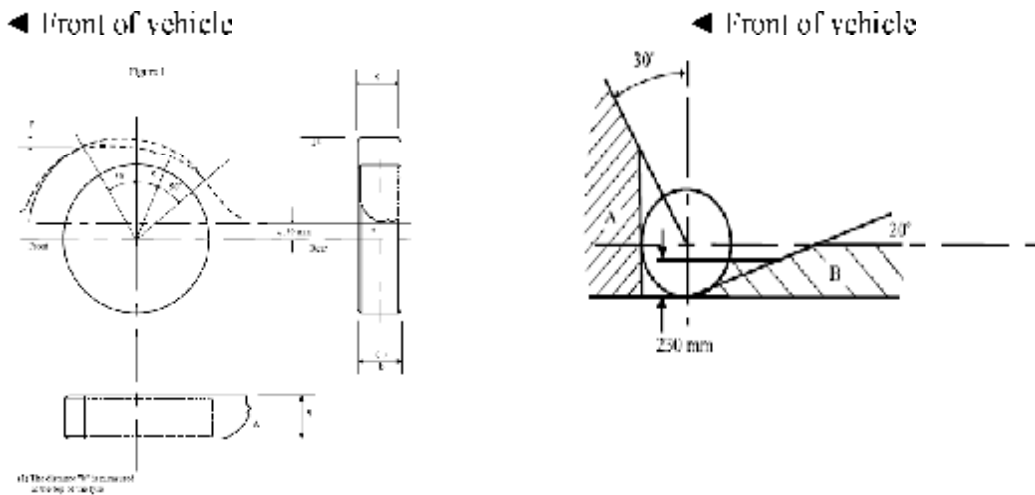

The wheel guards on the rearmost wheels must provide continuous protection between a point in area 'A' and a point in area 'B' in the figure above, and must cover the overall width of all tyres. In the case of steerable wheels, the requirements only apply when the wheels are in the straight-ahead position.

Where two or more axles form an axle group, separate wheel guards may be fitted to each wheel or a single wheel guard which provides continuous protection from area 'A' of the foremost wheel to area 'B' of the rearmost wheel may be used.

Wheel guards may consist of either permanent body structure or part structure and other components, including mudflaps. The end of a wheel guard including a mudflap (if fitted) need not be less than 230 mm from the ground.

Note



Wheel guards should be of sufficient structural strength to retain their function while the trailer is moving.

17.1. Visibility of Wheel Guards (Mudguards)

On every trailer which is 2.2 metres or more in width and which has a body of the tray type, that portion of the external surface of any rear wheel guard, which is visible to the rear, must be white or silver in colour and clearly visible.

18: VISIBILITY OF TRAY

On every trailer, which is 2.2 metres or more in width and which has a body of the tray type, and is not fitted with a rear marking plate. There must be displayed by painting or otherwise across the full width of the rearmost portion of the tray, a clearly visible white or silver coloured horizontal band having a uniform depth of at least 75mm.

Vehicle Standards Bulletin 1

19: AXLES AND SUSPENSIONS

Trailers may have axles at one or two locations.

If the trailer has 2 axle groups, the forward most axle group must be steerable by the drawbar.



Within a group of axles:

- two axles must not be more than 2 metres apart;
- three axles must not be more than 3.2 metres apart overall.

All axles in a group must be interconnected by a load sharing suspension except in a close-coupled axle group (where the two axles in a group have their centres not more than one metre apart, three axles not more than 2 metres apart or four or more axles not more than 3.2 metres apart) provided that the load carrying capacity of each axle in the group and the wheels and tyres fitted to it is:

- at least 120% of the load on that axle with the trailer at its ATM; and
- at least equal to the load on that axle with the trailer at its ATM and any retractable axle retracted.

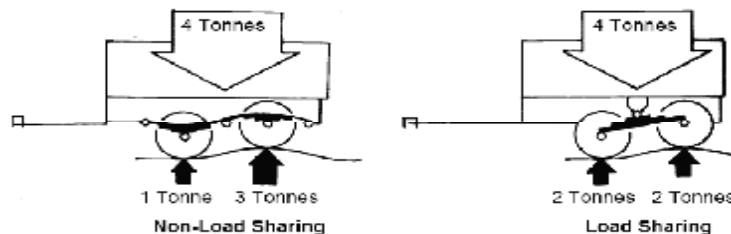

OR

Load sharing suspensions must be designed so that each axle in a group carries the same load irrespective of the relative movement of the wheels.

Caution



Leaf springs that are galvanised should only be used in corrosive environments and only when there are no better alternatives available. It is important not to overload trailers fitted with such leaf springs. Only purchase them from a supplier with adequate control over the galvanising process. Extreme care needs to be taken with the cleaning phase during galvanising, to reduce the risk of brittle failure while in service

Vehicle Standards Bulletin 1

20. WHEELS AND TYRES

All wheels and tyres must comply with ADRs 23 or 42, as relevant to the type of tyre used. Wheels and tyres must be adequate for the loads they are to carry and the speeds at which they are to be towed. The GTM of a trailer must not exceed the sum of the load ratings of its tyres.

Caution



Tyres marked 'NHS' are not for highway service and should not be used

20.1. Tyre Placard

Trailers with a GTM not exceeding 3.5 tonnes must have a tyre placard made of a durable material affixed to it in a prominent position. This may be affixed to or incorporated in to the vehicle plate referred to in Section 3. Tyres shall not be referred to by name of manufacturer or brand name on the placard. At least the following must be shown:

- the manufacturer's recommended tyre size;
- tyre load rating;
- speed rating;
- cold inflation pressures; and
- either the statement: 'The tyres fitted to this vehicle shall have a speed category not less than 'L' (120km/h)'; or
- if the recommended maximum vehicle operating speed is less than 120km/h, 'The tyres fitted to this vehicle shall have a speed category at least equal to the recommended maximum vehicle operating speed,'....'km/h.', where '....' is the vehicle manufacturer's recommended maximum vehicle operating speed.

20.2 Retreaded Tyres

If retreaded tyres are fitted to a trailer, the tyres shall comply with the requirements of Australian Standard [AS 1973 -1993](#) 'Pneumatic tyres - Passenger Car, Light Truck and Truck/bus - Retreading and repair process'

21 DIMENSIONS

All other trailer configurations and dimensions not specified in this VSB must comply with ADR 43.

21.1 Length

The length of a trailer, other than a semi-trailer, must not exceed 12.5 metres.

For a semi-trailer, the distance from the Point Of Articulation (POA) to the line from which the rear overhang is measured must not exceed 9.5 metres; and

- the forward projection from the POA must be contained within a radius of 1.9 metres; and
- the distance from the POA to the rear end must not exceed 12.3 metres.
- The length of a drawbar must not exceed 5 metres for a dog trailer or 8.5 metres for a pig trailer.

21.2 Rear Overhang

Dog Trailers

Rear overhang must not exceed the lesser of 3.7 metres or 60% of the wheelbase.

Vehicle Standards Bulletin 1

Semi-trailers

Rear overhang must not exceed the lesser of 3.7 metres or 60% of the distance between the point of articulation (POA) and the line from which the rear overhang is measured.

Other Trailers

Rear overhang must not exceed the lesser of 3.7 metres or the front load space.

21.3 Width

A trailer must not exceed 2.5 metres in overall width. The maximum distance is measured across the body including wheel guards, but excluding signalling devices and side-mounted lamps.

21.4 Height

The height of any trailer, except for a livestock trailer (See ADRs for definition) must not exceed 4.3 metres in height.

21.5 Ground Clearance

The ground clearance of a trailer measured from the horizontal road surface of any point on the underside of the trailer except the tyres, wheel and wheel hubs must, when unloaded, be not less than:

- 100 mm for any point in the width of the vehicle which is within one metre fore and aft of any axle; and
- when loaded, the dimension in millimetres obtained by multiplying the distance between any two consecutive axles in metres by 33.33, for the midpoint between those two axles.

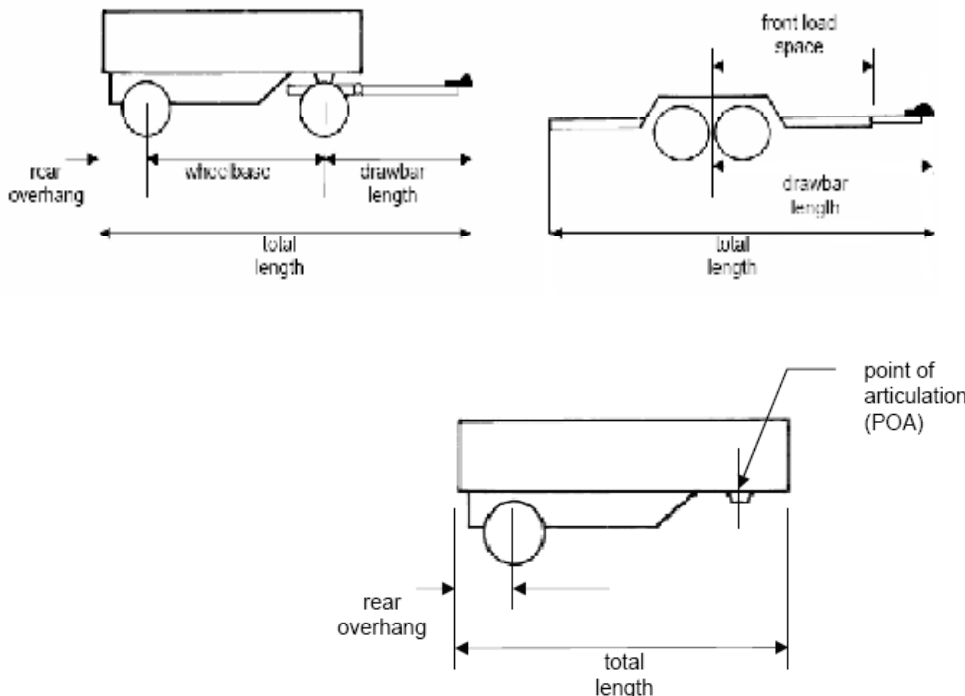

Vehicle Standards Bulletin 1

Note



Observance of permissible vehicle dimensions is critical to road safety. A trailer must meet the dimensional limits in order to take advantage of the arrangements under this bulletin. Otherwise, an approval under sections 10(A) or 16 of the Act must be obtained from the Department of Infrastructure, Transport, Regional Development and Local Government as well as a letter of authority from the relevant registration authority that confirms that the trailer will be permitted to be used on a public road.

22 GENERAL CARAVANS REQUIREMENTS

22.1 Doors

A caravan or trailer equipped with cooking facilities or living or sleeping accommodation must have only outward opening or sliding doors. **At least one such door must be located on the left-hand side or at the rear.**

22.2 LPG Installation

The local state or territory registering authority should be consulted for acceptability of LPG installations requirements. In cases where the local state and territory does not mandate a minimum requirement. Then Manufacturers are required to comply with *Australian Standard* [AS 5601-2004](#) 'Gas installations'.

22.3 Fire Extinguisher

Caravans must be provided with a fire extinguisher(s) selected and located in accordance with Australian Standards [AS1850-1994](#) – 'Portable Fire Extinguishers – Classification, Rating and

Performance Testing' or [AS 1850 -1997](#) 'Portable Fire Extinguishers – Classification, Rating and

Performance Testing' and [AS2444-1995](#) – 'Portable Fire Extinguishers and Fire Blankets –

Selection and Location or Australian Standard [AS 2444–2001](#) 'Portable fire extinguishers and fire blankets – Selection and location'.

Note



Fire authorities strongly recommend that caravans or trailers equipped with cooking facilities, or living or sleeping accommodation, be fitted with approved fire blankets and smoke detectors.

22.4 Toilets, Basins and Sinks

Refer to ADR 42 for more information on the fitment of lavatory closets, urinals, basins and sinks.

23. GENERAL REQUIREMENTS FOR TRAILERS

23.1 Carriage of Passengers

Trailers of any kind must not be designed or used for the carriage of passengers.

23.2 Internal or External Projections

No part of a trailer shall be hazardous to other road users; there must be no unduly sharp edges or projections.

Note



The use of toughened or laminated safety glass on trailers that have windows is strongly recommended.

Vehicle Standards Bulletin 1

23.3 Structural Requirements

There are no specific body structural requirements, but the trailer must be safe and fit for purpose.

Note



It is suggested as a minimum that the Manufacturer should be able to demonstrate that the structure is capable of supporting the designed payload with a safety factor of at least 3 for highway use and a safety factor of 5 for off road use.

23.4 Rear Bumper Bar

Semi-trailers must have a continuous rear bumper that is not more than 600 mm from the ground when the trailer is unloaded and which provides a force path to the trailer's structural members. Refer to ADR 42/04 clause 8 for further information.

24. TRAILERS & CARAVANS EQUIPPED WITH REFRIGERATION AND AIR CONDITIONING SYSTEMS

The Department of the Environment, Water, Heritage and the Arts has established specific requirements about vehicles equipped with an air conditioner. These vehicles may be subject to the provisions of the Ozone Protection and Synthetic Greenhouses Gas Management Act 1989.

Detailed information is available from:

www.deh.gov.au/atmosphere/ozone.

Alternatively, you should contact the Department on:

Ozone and Synthetic Gas Team

Department of the Environment, Water, Heritage and the Arts

GPO Box 787

CANBERRA ACT 2601

Phone: 02 6274 1373

Email: ozone@deh.gov.au

25 IMPORTING A TRAILER INTO AUSTRALIA

An import approval must be obtained for a vehicle to gain customs clearance at its point of entry to Australia. Vehicles that arrive in Australia without an import approval generally incur significant storage costs until an Import Approval is issued.

It is strongly recommended that you do not ship your vehicle to Australia until such time as you are issued with an Import Approval. If you ship your vehicle before receiving an approval and your vehicle arrives before the application is processed, you may incur storage costs from the shipping company/freight forwarder. You may also be open to prosecution, as it is an offence to import a vehicle without an import approval. Importation takes place when a vehicle is landed within the port of intended discharge and not once the vehicle clears customs control. If the import application is not approved, you will have to either export the vehicle or have it destroyed at your own expense. Destruction will need to take place under Customs supervision.

- For trailers with an ATM of less than 4.5 Tonnes (4,500kgs) please refer to Administrators Circular 0-2-7.
- For trailers with an ATM which exceeds 4.5 Tonnes (4,500kgs) please refer to Administrators Circular 0-3-6.

[\(For further information, please refer to Vehicle Standards Bulletin 10\)](#)

Vehicle Standards Bulletin 1

26. TO ORDER THE ADR CD-ROM

To order and make a payment for the ADR CD-ROM please complete the mailing details, select one of the payment methods described below, indicate the method on the form and fax or e-mail the completed form to **02 6274 7979** (from overseas + 61 2 6274 7979) to receive the ADR CD-ROM.

E-mail address: standards@infrastructure.gov.au

Mailing Details (Please print):

Contact Name: _____

Company Name: _____

Postal Address: _____

Suburb: _____ State: _____ Post Code: _____

Country: _____ Telephone No.: _____

Mobile Telephone No.: _____ Fax No.: _____

E-mail Address: _____

ADR CD-ROM	Costs	Qty	Total
For Australian Subscribers:			
With Subscription per year	\$70.60 (\$6.42 GST included).		
Without Subscription/One-Off	\$23.55 (\$2.14 GST included).		
For Overseas Subscribers:			
With Subscription per year	\$AUD64.18 (tax-free).		
Without Subscription/One-Off	\$AUD21.41 (tax-free).		

Please make your payment by one of the following methods:

- EFT your payment to: **Reserve Bank of Australia**, Canberra [swift: **RSKAU2S**]
Bank Details: **BSB: 092009** Account No. **110951** (Please quote 'ADRs' in the reference)
- Cheques to be made out to: **The Receiver of Public Monies**
Please mail your cheque and this form complete with all your details to:
ADR Subscriptions
Vehicle Safety Standards Branch – AL2E
Department of Infrastructure, Transport, Regional Development and Local Government
GPO Box 594
CANBERRA ACT 2601 AUSTRALIA
- Credit Card

Debit my card:

MasterCard

VISA

Card Number:

--	--	--	--

Expiry Date: ----- / -----

Name on card (Please print): _____

(Please sign): _____ (Card holder)

Office Use Only: Received Date: _____ Manual No.: _____ Despatched Date: _____

Vehicle Standards Bulletin 1

27. USEFUL CONTACTS

27.1 DEPARTMENT OF INFRASTRUCTURE, TRANSPORT, REGIONAL DEVELOPMENT AND LOCAL GOVERNMENT - VEHICLE IMPORTS TEAM.

GPO Box 594
CANBERRA ACT 2601
Phone: 1800 815 272 (Australia only) or
(02) 6274 7444
Fax: (02) 6274 6013
Internet: www.infrastructure.gov.au
E-mail: Vehicle Imports

27.2 AUSTRALIAN CUSTOMS SERVICE

Customs Information and Support Centre
General Enquiries: 1300 363 263 (Australia only)
+ 61 2 8339 6000 (Overseas only)
Fax: (02) 8339 6714

Postal Address:

Locked Bag 3000
Sydney International Airport
MASCOT NSW 2020

Street Address:

Customs House
10 Cooks River Drive
Sydney International Airport
MASCOT NSW 2020

Internet: www.customs.gov.au
E-mail: Australian Customs Service

27.3 AUSTRALIAN QUARANTINE & INSPECTION SERVICE

GPO Box 858
CANBERRA ACT 2601
Phone: (02) 6272 3999
Fax: (02) 6272 5888
Internet: www.daffa.gov.au
E-mail: Australian Quarantine & Inspection Service

27.4 AUSTRALIAN TAXATION OFFICE

Luxury Car Tax

GPO Box 9938
In Your Capital City
Phone: 1300 661 542
Internet: www.ato.gov.au
E-mail: Australian Tax Office

28 LOCAL STATE AND TERRITORY REGISTERING AUTHORITIES

NEW SOUTH WALES

27.5 ROADS AND TRAFFIC AUTHORITY, NSW

Centennial Plaza, 260 Elizabeth St, Surry Hills NSW 2010
(P.O. Box K198, Haymarket NSW 1240)
Phone: 13 22 13
Internet: www.rta.nsw.gov.au
E-mail: Roads and Traffic Registering Authority NSW

VICTORIA

27.6 VIC ROADS

60 Denmark Street
KEW VIC 3101
Phone: 13 11 71 (local) or (03) 9854 2666
Internet: www.vicroads.vic.gov.au
[E-mail VIC Roads](mailto:VIC Roads)

QUEENSLAND

27.7 QUEENSLAND TRANSPORT

Registration Division
GPO Box 1549
BRISBANE QLD 4001
Phone: 13 23 80 (local) or (07) 3253 4500
Fax: (07) 4982 0466
Internet: www.transport.qld.gov.au
[E-mail: Queensland Transport](mailto:Queensland Transport)

SOUTH AUSTRALIA

27.8 SA - DEPARTMENT FOR TRANSPORT, ENERGY AND INFRASTRUCTURE.

Vehicle Standards/Modifications/Engineering
PO Box 2526
REGENCY PARK SA 5942
Phone: 1300 882 248
Internet: www.transport.sa.gov.au
[E-mail: Department for Transport, Energy & Infrastructure](mailto:Department for Transport, Energy & Infrastructure)

WESTERN AUSTRALIA

27.9 WA - DEPARTMENT FOR PLANNING AND INFRASTRUCTURE

GPO Box R1290
Licensing Division
PERTH WA 6844
Phone: 13 11 56 (local) or (08) 9427 6404
Fax: 1300 669 995 or
from outside Australia +61 89427 8191
Internet: www.dpi.wa.gov.au
[E-mail: Department for Planning and Infrastructure](mailto:Department for Planning and Infrastructure)

TASMANIA

27.10 TAS DEPARTMENT OF INFRASTRUCTURE, ENERGY & RESOURCES

Registration & Licensing Department
GPO Box 1002
HOBART TAS 7001
Phone: 1300 851 225
Internet: www.dier.tas.gov.au
[E-mail: transport@dier.tas.gov.au](mailto:transport@dier.tas.gov.au)

NORTHERN TERRITORY

27.11 NT - THE DEPARTMENT OF PLANNING AND INFRASTRUCTURE

Motor Vehicle Registry
GPO Box 530
DARWIN NT 0801
Phone: 1300 654 628
Internet: www.nt.gov.au
[E-mail: mvr@nt.gov.au](mailto:mvr@nt.gov.au)

AUSTRALIAN CAPITAL TERRITORY

27.12 ACT - ROAD TRANSPORT AUTHORITY

PO Box 582
DICKSON ACT 2602
Phone: (02) 6207 7236
Fax: (02) 6267 6561
Internet: www.rego.act.gov.au
[E-mail: rus@act.gov.au](mailto:rus@act.gov.au)

Vehicle Standards Bulletin 1

28. APPENDIX 1



Australian Government

Department of Infrastructure, Transport,
Regional Development and Local Government

Motor Vehicle Standards (Trailers) Instrument 2008 (No. 1)

I, ROBERT HOGAN, Administrator of Vehicle Standards, make this instrument under sections 14A and 16 of the *Motor Vehicle Standards Act 1989*.

Dated 9 June 2009

A handwritten signature in blue ink, appearing to read 'R. Hogan', is written over a light blue rectangular background.

Robert Hogan
Administrator of Vehicle Standards

Vehicle Standards Bulletin 1

1 Name of Instrument

This Instrument is the *Motor Vehicle Standards (Trailers) Instrument 2008 (No. 1)*.

2 Commencement

This instrument commences when it is signed.

3 Definitions

(1) In this Instrument:

- **aggregate trailer mass** means the total mass of a road trailer when carrying the maximum load recommended by the manufacturer. This includes the mass imposed onto the towing vehicle when the combination vehicle is resting on a horizontal supporting plane.
- **the Act** means the *Motor Vehicle Standards Act 1989*.

(2) Unless the contrary intention appears, a word or expression that is used in this Instrument and in the Act has the same meaning in this Instrument as it has in the Act.

Note: The following terms are defined in the Act:

- new vehicle.
- road trailer.
- used imported vehicle.

4 Supply of nonstandard new trailers

(1) This approval is made under subsection 14A(1) of the Act.

(2) Road trailers:

- (a) that are new vehicles; and
- (b) with an aggregate trailer mass of 4.5 tonnes or less; and
- (c) that comply with the design and construction standards specified under Vehicle Standards Bulletin 1 issued on 1 December 2008; are approved for supply to the market.

(3) This approval is made subject to the condition that the road trailers comply with all necessary requirements for registration by a State or Territory Government for use on a public road.