

# FLEXIRIDE SUSPENSION UNITS

## Technical Data Sheet

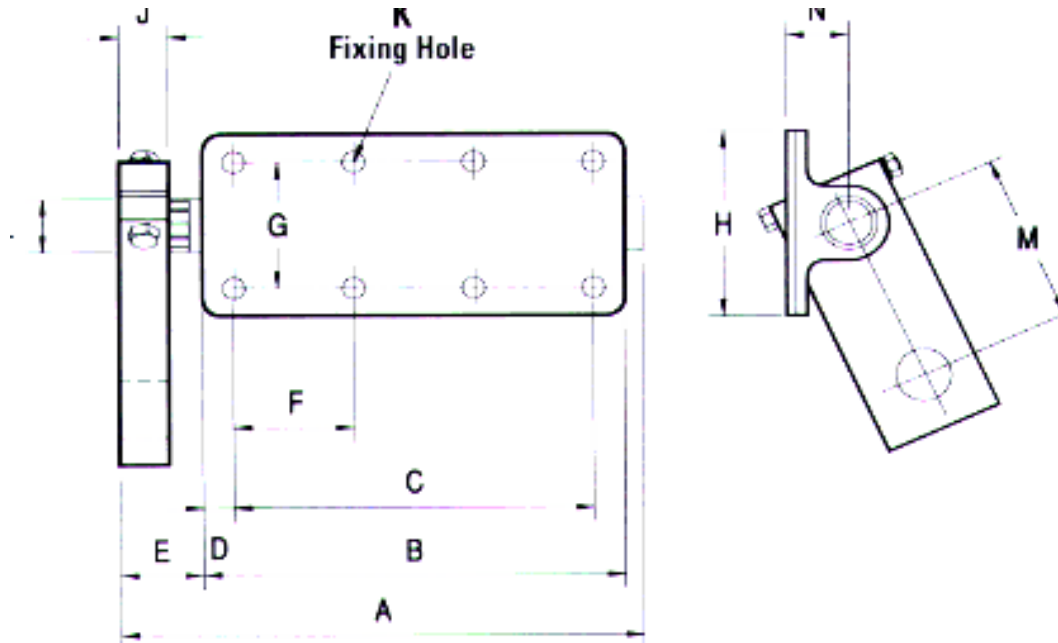

| Size/Ref Number |    | A   | B   | C   | D  | E  | F   | G   | H   | J  | K: Fixing for HT Bolts | L  | M   | N  |
|-----------------|----|-----|-----|-----|----|----|-----|-----|-----|----|------------------------|----|-----|----|
| 2/90            | mm | 188 | 140 | 121 | 10 | 38 | 60  | 60  | 79  | 25 | 6 x 5/16"              | 22 | 90  | 20 |
| 3/90            | mm | 222 | 178 | 159 | 10 | 38 | 79  | 73  | 92  | 25 | 6x 5/16"               | 25 | 90  | 22 |
| 4/90            | mm | 248 | 197 | 159 | 19 | 40 | 79  | 86  | 105 | 25 | 6 x 3/8"               | 29 | 90  | 25 |
| 6/90            | mm | 273 | 222 | 194 | 14 | 43 | 97  | 86  | 112 | 25 | 6 x 3/8"               | 32 | 90  | 29 |
| 10/115          | mm | 325 | 273 | 248 | 13 | 44 | 83  | 111 | 137 | 30 | 8 x 1/2"               | 38 | 115 | 35 |
| 14/115          | mm | 395 | 337 | 295 | 21 | 46 | 98  | 114 | 143 | 35 | 8 x 1/2"               | 41 | 115 | 37 |
| 21/115          | mm | 472 | 397 | 343 | 27 | 59 | 86  | 127 | 156 | 44 | 10 x 1/2"              | 44 | 115 | 41 |
| 33/115          | mm | 523 | 451 | 387 | 32 | 59 | 97  | 140 | 168 | 44 | 10 x 1/2"              | 51 | 115 | 48 |
| 50/115          | mm | 676 | 584 | 514 | 35 | 75 | 103 | 171 | 203 | 57 | 12 x 1/2"              | 60 | 115 | 56 |

| BASEPLATE       |              | CAPACITIES         |                      | TORQUE - Pinch Bolt  |             |                                   |
|-----------------|--------------|--------------------|----------------------|----------------------|-------------|-----------------------------------|
| Size/Ref Number | Product Code | Arm Centres (M) mm | Capacity Per Pair kg | Bolt Size inches/UNF | Torque Kgms | Nominal Tor-tional Rate Nm/Degree |
| 2/90            | FS2          | 90                 | 250                  | 5/16                 | 2.4         | 6.40                              |
| 3/90            | FS3          | 90                 | 425                  | 3/8                  | 4.2         | 10.00                             |
| 4/90            | FS6          | 90                 | 600                  | 3/8                  | 4.2         | 12.70                             |
| 6/90            | FS9          | 90                 | 750-900              | 1/2                  | 9.8         | 18.50                             |
| 10/115          | FS13         | 115                | 1000-1300            | 5/8                  | 19.4        | 26.20                             |
| 14/115          | FS18         | 115                | 1500-1800            | 5/8                  | 19.4        | 49.00                             |
| 21/115          | FS23         | 115                | 2000-2300            | 3/4                  | 34.6        | 63.60                             |
| 33/115          | FS30         | 115                | 2400-3000            | 3/4                  | 34.6        | 140.00                            |
| 55/115          | FS50         | 115                | 5000                 | 1                    | 83          | 140.00                            |